

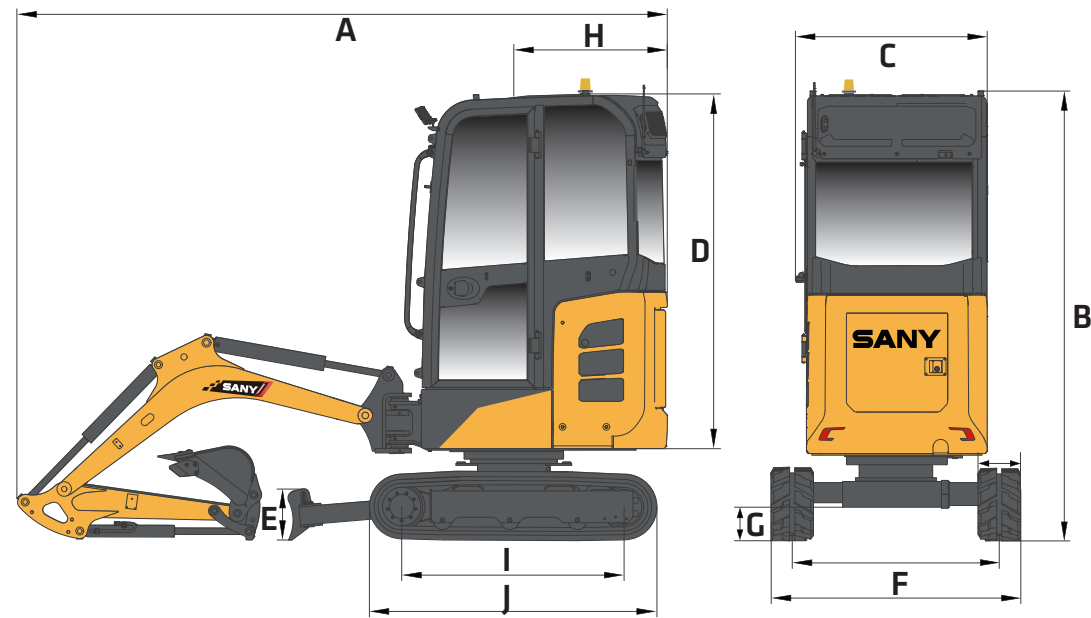

SY20U

SWING BOOM HYDRAULIC EXCAVATOR **4,464 LBS** OPERATING WEIGHT
19.6 HP GROSS HORSEPOWER
8' 6" MAX DIGGING DEPTH



TECHNICAL SPECIFICATIONS

MACHINE DATA	STANDARD STICK
Operating Weight*	4,464 lbs
Bolt-on Counterweight	-
Ground Pressure	4.6 psi
Engine Model	3TNV80F
Displacement	77.3 in3
Net Power	18.2 HP@2,400 rpm
Gross Power	19.6 HP@2,400 rpm
Hydraulics	Load Sensing with Pilot Control
Main Hydraulic Pump	Axial Piston-Variable Displacement
Operating Flow (Max)	17.4 gpm
Operating Pressure (Max)	3,553 psi
Auxiliary Flow	10.6 gpm
Auxiliary Pressure	3,626 psi
Travel Motor	Axial Piston with Park Brake
Travel Pressure (Max)	3,481 psi
Travel Speeds (Max)	2.5/1.7 mph (AC off) 1.9/1.3 mph (AC off)
Travel Effort (Max)	3,642 lbf
Gradability	30 deg.
Swing Motor	Axial Piston with Swing Brake
Swing Pressure (Max)	2,700 psi
Swing Speed (Max)	10 rpm
Undercarriage	Belted Rubber Track
Track Shoe Width	9"
Track Rollers	3 per side
Carrier Rollers	-

DIMENSIONS	STANDARD STICK
Boom Length	5' 10"
Stick Length	3' 10"
A Transport Length	12' 1"
B Transport Height	8'
C Upper Structure Width	3' 5"
D Cab Height	8'
E Blade Height	10"
F Track Width	3' 5"/4'5"
Track Gauge	2' 6"/3' 8"
G Ground Clearance	6"
H Tail Swing Radius	3'
I Track Length on Ground	4'
J Track Length	5' 2"

SERVICE REFILL CAPACITIES	
Fuel Tank Capacity	6.60 gal
DEF Tank Capacity	-
Hydraulic Tank Capacity	5.55 gal
Engine Oil Capacity	0.90 gal
Cooling System Capacity	1.43 gal

In the interest of continual equipment development, SANY America Inc. reserves the right to change these specifications at any time without prior notification.
 ©2026 SANY America Inc. HEXPS26SY20U001



*Warranty applies to 2026 Excavator and Wheel Loader models



SANY America Inc. 318 SANY Way
 Peachtree City, Georgia 30269
 470.552.SANY sanyamerica.com

sanyamerica.com ||| SY20U

WORKING SPECIFICATIONS

WORKING RANGE	STANDARD STICK
Boom Length	5' 10"
Stick Length	3' 10"
A Maximum Digging Height	11' 7"
B Maximum Dumping Height	8' 1"
C Maximum Digging Depth	8' 6"
D Maximum Vertical Wall Digging Depth	7' 3"
E Maximum Reach at Ground Level	13' 2"
F Minimum Swing Radius	5' 5"

DIGGING PERFORMANCE	STANDARD STICK
Boom Length	5' 10"
Stick Length	3' 10"
Bucket Breakout Force (ISO)	3,732 lbf
Stick Digging Force (ISO)	2,068 lbf

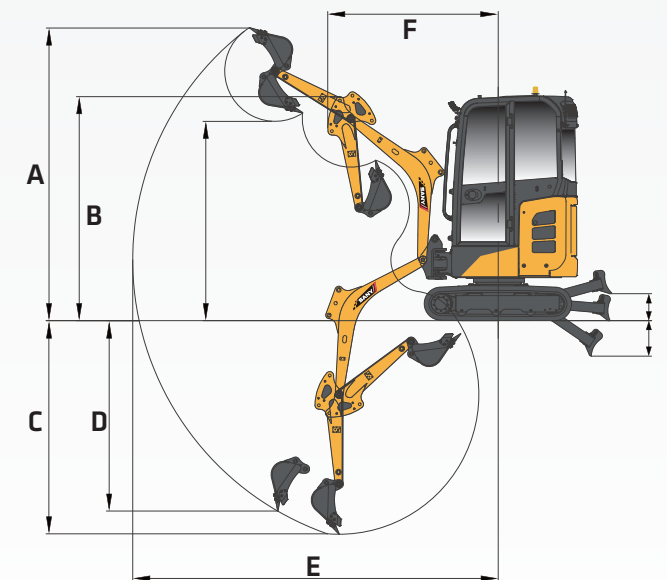

*Operating weight is for the SY20U with no attachments, and standard stick.

SANY America Inc. reserves the right to change these specifications at any time without prior notification. ©2026 SANY America Inc. HEXPS26SY20U001

sanyamerica.com ||| SY20U

SWING BOOM HYDRAULIC EXCAVATOR SY20U

STANDARD FEATURES

ENGINE

- Yanmar 3TNV80F
- Tier 4f / EU Stage V Ready
- Auto-idle
- Dual-element dry air filter
- Coolant Expansion tank
- EGR Valve
- Fan guard
- Engine coolant to -37 deg. C (-34 deg. F)
- Full-flow oil filter
- High flow cooling fan
- 500-hour engine-oil-change interval
- Fuel filter and water separator

HYDRAULIC SYSTEM

- Spring-applied, hydraulically released automatic swing brake
- Load sensing hydraulic system
- Control pattern change valve
- Primary auxiliary hydraulic circuit with flow diverter and 1 and 2-way piping
- Auxiliary hydraulic-flow adjustments through monitor
- Adjustable auxiliary pressure relief
- Quick coupler plumbing to end of the stick

UNDERCARRIAGE

- Planetary drive with axial piston motors
- Propel motor shields
- Spring-applied, hydraulically released automatic propel brake
- Track guides, front idler and 2 per side
- 2-speed travel selection through display and on dozer lever
- 3 lower track rollers each side
- 1 Upper carrier roller each side
- Dozer blade with float function and cylinder guarding
- Tie downs on track frame and dozer blade
- 230 mm (9") wide rubber tracks
- Undercarriage frame opening guard

UPPERSTRUCTURE

- Right-hand, left-hand, and counterweight mirrors
- Lockable cab, hood, and service doors
- Debris screen in side panel
- Remote-mounted engine oil and fuel filters
- Daily fluid level inspection visible from ground
- Rear reflectors

ATTACHMENTS

- Convenient grease points
- Dirt seals on all bucket pins
- Flow diverter valve

ATTACHMENTS

- Thumb bracket
- Oil-impregnated bushings
- Reinforced thrust plates

OPERATOR'S STATION

- Hydraulic pilot controls for boom, stick, swing, and travel operations
- Proportional auxiliary switches on joystick
- Travel levers with foot pedals
- AM/FM radio with bluetooth and USB connection port
- Vinyl seat with fore/aft adjustment
- 2" retractable seat belt
- Emergency stop switch
- Sliding front window
- Removable lower front window
- Window breaker
- Standard and Breaker work mode
- 8 tool selection modes
- Fully adjustable auxiliary flow circuit from display
- Multifunction LCD monitor with: diagnostic capability / multiple-language
- System monitoring features: auto-idle indicator, 2-speed indicator, work tool mode indicator preheat icon, time and date, battery charge icon, throttle position, engine oil pressure alarm, fuel level gauge, maintenance needed icon, failure code, standard/breaker mode button, engine coolant temperature, coolant temp alarm, severe failure alarm, operating hours
- High performance heating, ventilation, and air conditioning system
- Operation and maintenance manual storage
- Heavy duty removeable rubber floor mat
- Front windshield wiper with high and low speed
- Horn, electric
- Hour meter, electric
- Hydraulic shutoff lever, all controls
- Interior light
- Cup holder
- Travel alarm with cancel switch
- Transparent overhead window

ELECTRICAL

- 12V electrical system
- Maintenance free battery
- Ground level battery disconnect
- Easy access fuse panel
- Terminal battery covers
- 80-amp alternator
- 12V power outlet

LIGHTS

- Work lights: 3 mounted on top of cab, 1 mounted on boom, magnetic beacon

LIFTING PERFORMANCE

- Standard 5' 10" Boom
- Standard 3' 10" Stick
- Standard 9" Track Shoes
- No Bucket

Ratings are based on ISO 10567:2007. Lift capacity does not exceed 75% of tipping load with the machine on firm, level ground or 87% of hydraulic lifting capacity.

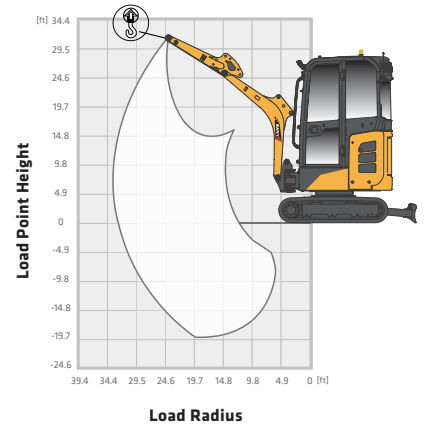
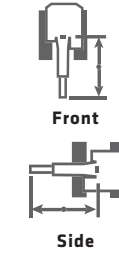

Blade Up

B (HEIGHT)	4.9 FT		6.6 FT		8.2 FT		16.4 FT		MAX	
LOAD POINT HEIGHT										
9.8 ft									*633 lbs	*633 lbs
6.6 ft							637 lbs	*719 lbs	*489 lbs	*489 lbs
3.3 ft			1,133 lbs	*1,210 lbs	807 lbs	915 lbs	613 lbs	694 lbs	465 lbs	*489 lbs
0.0 ft	*1,499 lbs	*1,499 lbs	1,027 lbs	1,175 lbs	747 lbs	855 lbs	578 lbs	661 lbs	463 lbs	531 lbs
-3.3 ft			1,014 lbs	1,162 lbs	734 lbs	840 lbs	573 lbs	657 lbs	560 lbs	642 lbs

Blade Down

B (HEIGHT)	4.9 FT		6.6 FT		8.2 FT		16.4 FT		MAX	
LOAD POINT HEIGHT										
9.8 ft									*633 lbs	*633 lbs
6.6 ft							*719 lbs	*719 lbs	*489 lbs	*489 lbs
3.3 ft			*1,210 lbs	*1,210 lbs	*983 lbs	915 lbs	*869 lbs	694 lbs	*489 lbs	*489 lbs
0.0 ft	*1,499 lbs	*1,499 lbs	*1,790 lbs	1,175 lbs	*1,259 lbs	855 lbs	*961 lbs	661 lbs	*567 lbs	531 lbs
-3.3 ft			*1,493 lbs	1,162 lbs	*1,074 lbs	840 lbs	*772 lbs	657 lbs	*734 lbs	642 lbs