

ENGINE		
Engine Model	Yanmar 3TNV86CT-DTY	
Emission	T4f/Stage V	
Rated Gross Power	43 HP @ 3,000 RPM	32.4 kW @ 3,000 RPM
Max Torque	87-95±18/1950ft-lb/rpm	118.6-128.9/1950(±25)Nm/rpm
Low Idle / High Idle	1000 / 3,150 RPM	17 Hz / 52.5 Hz
Displacement	0.42 gal	1.57 L
# of Cylinders	3	

WEIGHTS		
Operating Weight	8,179 lbs	3 710 kg
Weight of Front Drum	3,924 lbs	1 780 kg
Weight at Rear Drum	4,254 lbs	1 930 kg

ELECTRICAL		
Battery	Model	6-QW-60
	Voltage	12V
	CCA	640 CCA
	Capacity	60 Ah
Alternator	Amp	55 Amp
	Voltage	12V
Power Outlet	Voltage	12V
	USB	5V

VIBRATORY SYSTEM		
Frequency	55 / 67 Hz	
Amplitude	0.43 mm	
Static Line Load of Front Drum	74 lb/in	129.5 N/cm
Static Line Load of Rear Drum	80 lb/in	140.0 N/cm
Exciting Force	6,295 / 10,341 lb	28 / 46 kN

In the interest of continual equipment development, SANY America Inc. reserves the right to change these specifications at any time without prior notification.

DRIVE SYSTEM		
Gradeability Smooth Drum	30/40%	
Articulation	+/- 32°	
Oscillation Angle	+/- 10°	
Service Brakes	Hydrostatic through propulsion system	
Parking Brakes	Spring-applied, hydraulically released	
Max. Travel Speed	7.5 mph	12 km/h

SERVICEABILITY AND FILL CAPACITIES		
Fuel Tank	15.8 gal	60.0 L
Hydraulic Tank	13.2 gal	50.0 L
Engine Oil (with filter)	2.6 gal	10.0 L
Water Tank	60.75 gal	230 L

SOUND LEVEL	
Operator's Ear in the Cab	88 db
External	104 db

WATER SYSTEM	
Type	Pressurized
Nozzles	5 per drum
Filtration	100 mesh inline, 50 mesh nozzles
Drum Wiper	Spring-loaded, self adjusting polyurethane

DUAL DRUM ROLLER

STR40

STANDARD FEATURES

- ➔ Components from brands you trust like Yanmar engines and Poclain hydraulic motors for dependable performance
- ➔ Clear lines of sight and suspension seat offer operator comfort and job site safety
- ➔ Auto vibration
- ➔ Self-adjusting drum wipers
- ➔ Maintenance free articulation joint

**43 hp**  
Net Power  
**8,179 lbs**  
Operating Weight  
**54.13"**  
Drum Width

DIMENSIONS

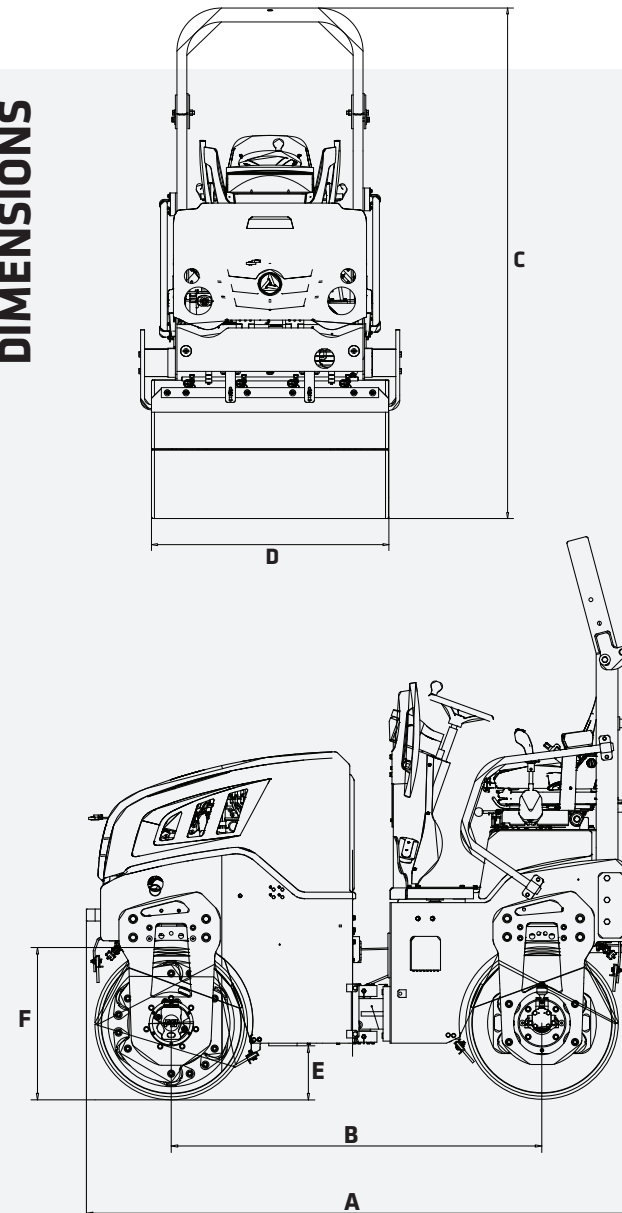

OVERALL DIMENSIONS

<b>A</b> Overall Length	8' 4"	2 544 mm
<b>B</b> Wheelbase	5' 7"	1 700 mm
<b>C</b> Overall Height	8' 6"	2 585 mm
<b>D</b> Drum Width	54.13"	1 375 mm
Overall Width	4' 11"	1 485 mm
<b>E</b> Ground Clearance	9.64"	245 mm
<b>F</b> Drum Diameter	27.7"	704 mm
Drum Shell Thickness	0.6"	16 mm
Min. Inside Turning Radius	8' 8"	2 650 mm
Curb Clearance	9.64"	245 mm



\*Warranty applies to 2024 Crane, Telehandler, Grader and Roller models only.

PRODUCT SPECIFICATIONS ROLLER ||| STR40



STANDARD FEATURES

s = standard

STR40	POWERTRAIN
s	43HP Yanmar Engine
s	Dual-element dry air filter
s	Electronic engine control
s	Fuel filter with water separator
s	Full-flow oil filter
s	Turbocharger with charge air cooler
s	500-Hour engine-oil-change interval
s	Engine air precleaner
VIBRATORY SYSTEM	
s	Selectable vibration: front, both
s	Dual amplitude, dual frequency
s	Auto vibration function
s	Inside scraper- urethane
s	Outside scraper- urethane
ELECTRICAL	
s	12 Volt electrical system
s	Ground level electrical disconnect (lockout tag out)
s	640 Cold cranking amps battery capacity
s	Battery terminal covers
s	Back-up alarm
s	Emergency STOP
s	Beacon light

PRODUCT SPECIFICATIONS ROLLER ||| STR40



STANDARD FEATURES

s = standard

STR40	OPERATOR'S STATION
s	Open platform with handrails/guardrails
s	Anti-slip floor
s	Battery disconnect switch
s	Operator presence sensor
s	Sliding operator seat
s	3" Seatbelt
s	Foldable arch ROPS
s	Steering Knob
s	12 Volt outlets 60 watt 5 amp
s	5 Volt USB
s	Illuminated gauge: Water level, engine coolant, and fuel levels
s	Horn
s	Hour meter, electric
s	Multifunction color LCD monitor with: Diagnostic capability / Multiple-language
s	Dual lever control for travel and vibration
s	Engine check, engine coolant temperature indicator
s	Light with audible alarm, engine oil pressure indicator light with audible
s	Alarm, low-alternator-charge indicator light, low-fuel indicator light
s	Indication with audible alarm, fault code alert indicator, fuel-rate display
s	Work-lights-on indicator
s	Suspension seat
s	Hydraulic oil filter restriction indicator light
s	Cup holder
WATER SYSTEM	
s	Hand serviceable spray nozzles
s	Adjustable spray flow rate
s	Water strainer
LIGHTS	
s	LED work lights
s	Indicator and hazard lights