

# PRODUCT SPECIFICATIONS LARGE EXCAVATOR || SY750H

## WORKING RANGE

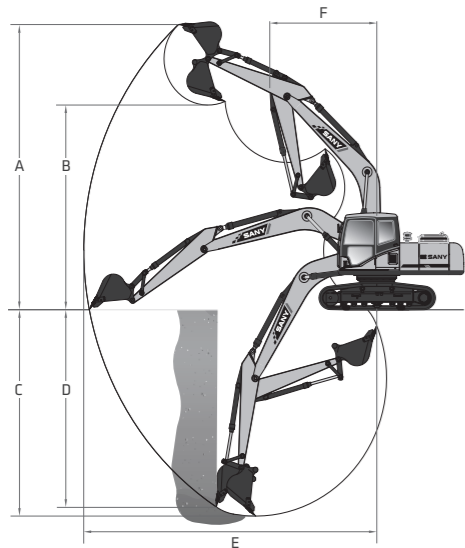

WORKING RANGE			
Boom Length	23'	7 000	mm
Stick (Arm) Length	9' 10"	3 000	mm
A Maximum Digging Height	36' 2"	11 020	mm
B Maximum Dumping Height	23' 6"	7 170	mm
C Maximum Digging Depth	24' 10"	7 580	mm
D Maximum Vertical Wall Digging Depth	16'	4 890	mm
E Maximum Reach at Ground Level	39' 8"	12 100	mm
F Minimum Swing Radius	17' 8"	5 390	mm
DIGGING PERFORMANCE			
Boom Length	23'	7 000	mm
Stick (Arm) Length	9' 10"	3 000	mm
Bucket Breakout Force (ISO)	92,172 lbf	410.0	kN
Stick (Arm) Digging Force (ISO)	79,582 lbf	354.0	kN

## LIFTING PERFORMANCE

Standard 23' (7 000 mm) Boom  
Standard 9' 10" (3 000 mm) Stick  
Standard 26" (650 mm) Track Shoes  
No Bucket

Ratings are based on ISO 10567:2007. Lift capacity does not exceed 75% of tipping load with the machine on firm, level ground or 87% of hydraulic lifting capacity.

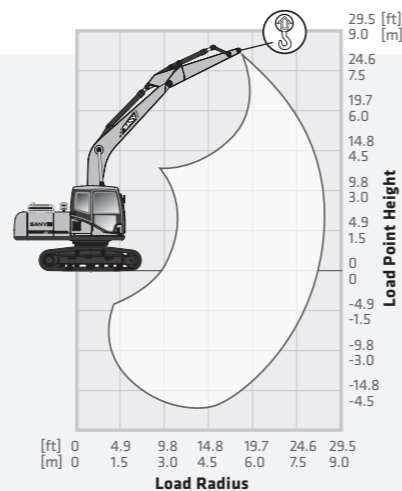
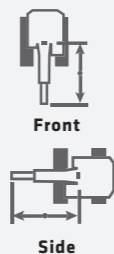

LOAD RADIUS	4.9 FT 1.5 M	9.8 FT 3.0 M	14.8 FT 4.5 M	19.7 FT 6.0 M	24.6 FT 7.5 M	29.6 FT 9.0 M	HORIZONTAL MAX REACH	
LOAD POINT HEIGHT	Front		Side		Front		Side	
29.6 ft 9.0 m							38,017 lbs 17 244 kg	38,017 lbs 17 244 kg
24.6 ft 7.5 m					37,340 lbs 16 937 kg	37,340 lbs 16 937 kg	36,608 lbs 16 605 kg	36,608 lbs 16 605 kg
19.7 ft 6.0 m				68,917 lbs 31 260 kg	58,453 lbs 26 514 kg	39,194 lbs 17 778 kg	39,194 lbs 17 778 kg	36,286 lbs 16 459 kg
14.8 ft 4.5 m				50,753 lbs 23 021 kg	50,753 lbs 23 021 kg	42,177 lbs 19 131 kg	42,177 lbs 19 131 kg	37,364 lbs 16 948 kg
9.8 ft 3.0 m				56,562 lbs 25 656 kg	56,562 lbs 25 656 kg	45,279 lbs 20 538 kg	45,279 lbs 20 538 kg	38,801 lbs 17 600 kg
4.9 ft 1.5 m				60,144 lbs 27 281 kg	60,144 lbs 27 281 kg	47,532 lbs 21 560 kg	47,532 lbs 21 560 kg	39,813 lbs 18 059 kg
0 ft 0 m			64,946 lbs 29 459 kg	64,946 lbs 29 459 kg	60,737 lbs 27 550 kg	60,737 lbs 27 550 kg	48,178 lbs 21 853 kg	41,026 lbs 18 609 kg
-4.9 ft -1.5 m		47,763 lbs 21 665 kg	47,763 lbs 21 665 kg	74,567 lbs 33 823 kg	74,567 lbs 33 823 kg	58,359 lbs 26 471 kg	58,359 lbs 26 471 kg	46,562 lbs 21 120 kg
-9.10 ft -3.0 m		80,885 lbs 36 689 kg	80,885 lbs 36 689 kg	65,859 lbs 29 873 kg	65,859 lbs 29 873 kg	52,525 lbs 23 825 kg	52,525 lbs 23 825 kg	41,326 lbs 18 745 kg
-14.8 ft -4.5 m			51,575 lbs 23 394 kg	51,575 lbs 23 394 kg	40,766 lbs 18 491 kg	40,766 lbs 18 491 kg		35,719 lbs 16 202 kg

\*Based on theoretical calculation at max flow with no load. Subject to alterations. In the interest of continual equipment development, SANY America Inc. reserves the right to change these specifications at any time without prior notification.  
©2023 SANY America Inc. HEXPS23SY750H001

# PRODUCT SPECIFICATIONS



# LARGE EXCAVATOR || SY750H

## STANDARD FEATURES

- ➔ Dual swing drives
- ➔ 1-way and 2-way primary auxiliary and 2-way secondary auxiliary circuits with dedicated auxiliary rotate pump
- ➔ 10.4" touchscreen display
- ➔ Heated air ride seat with adjustable independent control positions
- ➔ Blind side and rear view cameras
- ➔ Powerful Cummins Engine

**524 hp**  
Gross Power  
**24' 10"**  
Dig Depth  
**173,063 lbs**  
Operating Weight  
**92,172 lbf**  
Bucket Breakout

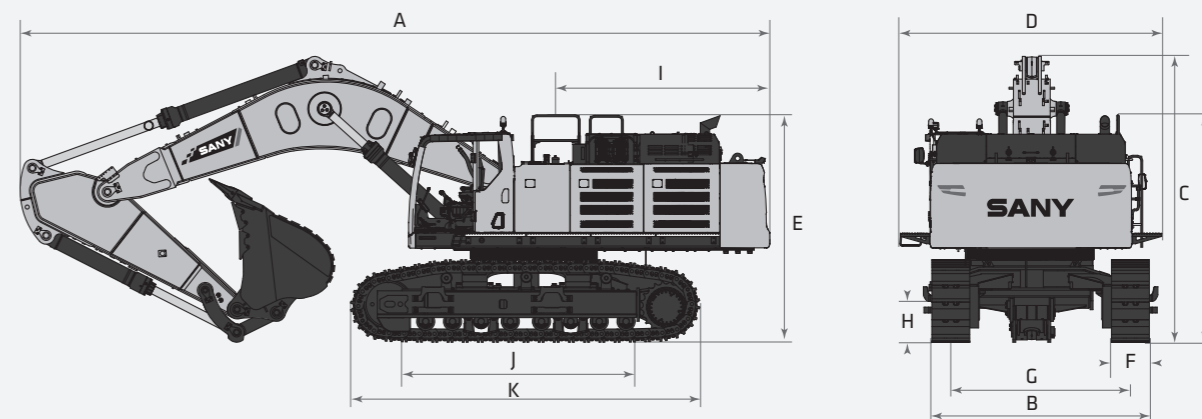

## TECHNICAL SPECIFICATIONS

TECHNICAL SPECIFICATIONS		
Operating Weight	173,063 lbs	78 500 kg
Ground Pressure	14.6 psi	101.0 kPa
<b>Engine</b>	Cummins X15 Stage V / Tier4F	
Displacement	909.3 in <sup>3</sup>	14.9 L
Gross Power	524 HP	391 kW
<b>Hydraulics</b>	Positive Flow w/Pilot Control	
Main Hydraulic Pump	Axial Piston - Variable Displacement	
Operating Flow (maximum) 2@504 L/min	266.3 gal/min	1 008.0 L/min
Operating Pressure (maximum)	4,975 psi	34.3 MPa
Travel Pressure (maximum)	4,975 psi	34.3 MPa
Slew Pressure	4,134 psi	28.5 MPa
Pilot Pressure	566 psi	3.9 MPa
<b>Travel Motor</b>	Axial Piston with Park Brake	
Travel Pressure (maximum)	4,975 psi	34.3 MPa
Travel Speeds (maximum)	1.8 / 2.8 mph	2.9 / 4.5 km/hr
Travel Effort (maximum)	122,926 lbf	546.8 kN
Grade Capability (maximum)	35°	
<b>Swing Motor</b>	Axial Piston with Swing Brake	
Swing Pressure (maximum)	4,134 psi	28.5 MPa
Swing Speed (maximum)	7.2 RPM	
<b>Undercarriage (standard)</b>	Steel Track	
Track Shoe Width (standard)	26"	650 mm
Track Rollers (per side)	8	
Carrier Rollers (per side)	3	

\*Based on theoretical calculation at max flow with no load. Subject to alterations. In the interest of continual equipment development

## DIMENSIONS

DIMENSIONS		
Boom Length	23'	7 000 mm
Stick (Arm) Length	9' 10"	3 000 mm
A Transport Length	42' 3"	12 879 mm
B Transport Width	12'	3 499 mm
C Transport Height	16' 4"	4 981 mm
D Upper Structure Width (with step)	14' 8"	4 479 mm
E Cab Height	12' 5"	3 795 mm
F Track Width (standard shoe)	26"	650 mm
G Track Gauge	11' 1"	3 380 mm
H Ground Clearance	2' 11"	892 mm
I Tail Swing Radius	13' 8"	4 175 mm
J Track Length on Ground	15' 8"	4 770 mm
K Track Length	19' 8"	5 986 mm
SERVICE REFILL CAPACITIES		
Fuel Tank Capacity	248.3 gal	940.0 L
DEF Tank Capacity	26.4 gal	100.0 L
Hydraulic Tank Capacity	179.6 gal	680.0 L
Engine Oil Capacity	9.6-11.3 gal	36.5-43 L
Cooling System Capacity	19.8 gal	75.0 L

SANY America Inc. reserves the right to change these specifications at any time without prior notification. ©2023 SANY America Inc. HEXPS23SY750H001

s = standard / o = optional

SY750H	ENGINE
s	14.9l Cummins X15
s	Auto-idle
s	Dual-element dry air filter
s	Batteries 24V (2-12V)
s	Coolant Expansion tank
s	Electronic engine control
s	Enclosed fan guard
s	Engine coolant to -37 deg. C (-34 deg. F)
s	Fuel filter with water separator
s	Full-flow oil filter
s	Turbocharger with charge air cooler
s	High flow electric clutch actuated fan
s	500-hour engine-oil-change interval
s	70% (35 deg.) off-level capability
s	Engine air precleaner
s	Severe-duty fuel filter
HYDRAULIC SYSTEM	
s	Spring-applied, hydraulically released automatic swing brake
s	Auxiliary hydraulic-flow adjustments through monitor
s	Lift power boost on joystick
s	Control pattern change valve
s	Auxiliary hydraulics with 1 and 2-way combination piping for high flow
s	Auxiliary hydraulics with 2-way rotation piping and controls
s	Auxiliary pilot and electric controls
s	Quick coupler plumbing and control
UNDERCARRIAGE	
s	Planetary drive with axial piston motors
s	Propel motor shields
s	Spring-applied, hydraulically released automatic propel brake
s	Track guides, front idler and 2 additional per side
s	2-speed travel selection
s	Upper carrier rollers (3)
s	Sealed and lubricated track chain
s	Double semi-grouser shoes, 650 mm (25.6")
s	Undercarriage frame opening guard
BOOM & STICK	
s	Boom 7.0 m
s	Arm 3.0 m
UPPERSTRUCTURE	
s	Right-hand, left-hand
o	Counterweight mirrors
s	Vandal lock with ignition key: Cab door / Service door / Toolbox / Cab Filter
s	Debris screen in side panel
s	Remote-mounted engine oil and fuel filters
s	Heavy duty triangle channel frame guard
ATTACHMENTS	
s	Convenient grease points
o	Centralized lubrication system

In the interest of continual equipment development, SANY America Inc. reserves the right to change these specifications at any time without prior notification.  
©2023 SANY America Inc. HEXPS23SY750H001

s = standard / o = optional

SY750H	ATTACHMENTS CONTINUED
s	Dirt seals on all bucket pins
s	Oil-impregnated bushings
s	Reinforced resin thrust plates
o	Quick coupler
o	Buckets: Heavy duty / Heavy-duty high capacity / Side cutter and teeth
OPERATOR'S STATION	
s	Adjustable independent-control positions (levers-to-seat, seat-to-pedals)
s	AM/FM radio with USB charging and Bluetooth® connectivity
s	Auto climate control/air conditioner/heater/pressurizer
s	Built-in Operator's Manual storage compartment and manual
s	12V and 24V outlets 60 watt 5 amp
s	Deluxe heated air suspension cloth seat with adjustable armrests
s	Heavy duty rubber floor mat
s	Front windshield wiper with intermittent speeds
s	Touchscreen Monitor 10". Displays Fuel, DEF, Engine temp, Oil temp.
s	Horn, electric
s	Hour meter, electric. In touch screen.
s	Hydraulic shutoff lever, all controls
s	Interior light
s	Digital Power mode selection: 3 power modes- low, standard, and high
s	Digital tool selection: bucket, shear, hammer, etc.
s	Multifunction color LCD monitor with: Diagnostic capability / Multiple-language / Maintenance tracking / Clock
s	System monitoring with alarm features: Auto-idle indicator, engine air cleaner restriction indicator light, engine check, engine coolant temperature indicator light with audible alarm, engine oil pressure indicator light with audible alarm, low-alternator-charge indicator light, low-fuel indicator light, low DEF indication with audible alarm, fault code alert indicator, fuel-rate display, wiper-mode indicator, work-lights-on indicator, and work-mode indicator
s	Motion alarm with cancel switch (conforms to SAE J994)
s	Power-boost switch on right joystick
s	Auxiliary hydraulic control switches in right console lever
s	Seat belt, 2", non-retractable
s	Transparent overhead hatch
s	Heated or cooled food/beverage storage
s	Air-suspension heated seat
s	Hydraulic oil filter restriction indicator light
o	Protection screens for cab front, rear, and side
ELECTRICAL	
s	60-amp alternator
s	Ground level electrical disconnect (lockout tag out)
s	Blade-type multi-fused circuits
s	Positive-terminal battery covers
s	Rearview camera
LIGHTS	
s	Work lights: High power LED - 4 mounted on boom, 2 mounted on top of cab, 1 mounted under step on right side of machine

In the interest of continual equipment development, SANY America Inc. reserves the right to change these specifications at any time without prior notification.  
©2023 SANY America Inc. HEXPS23SY750H001



\*Warranty applies to 2023 Excavator and Wheel Loader models only

