

ENGINE		
Engine Model	Yanmar 4TNV98CT-VSY	
Emission	Stage V	
Rated Gross Power	72 HP @ 2,100 RPM	53.7kW @ 2100 RPM
Rated Net Power	68 HP @ 2,100 RPM	50.9kW @ 2100 RPM
Max Torque	214 lb-ft	290 N.m @ 1350 RPM
Low Idle / High Idle	1000 rpm / 2250 rpm	1000 rpm / 2250 rpm
Displacement	0.88 gal	3.318 L
Stroke	4.3"	110 mm
Bore	3.9"	98 mm
# of Cylinders	4	
Max. Travel Speed	0-2/0-3 mph; 0-4/0-6 mph	0-6.5/0-7 km/h; 0-8.5/0-12.3 km/h

WEIGHTS		
Operating Weight	15,752 lbs	7 135 kg
Weight at Drum	7,831 lbs	3 552 kg
Weight at Axle	7,899 lbs	3 583 kg
Weight with Padfoot Kit	17,130 lbs	7 770kg

ELECTRICAL		
Battery	Model	6-QW-120MF
	Voltage	12V
	CCA	850 Amp
	Capacity	120 Ah
Alternator	Amp	70 Amp
	Voltage	24V
Power Outlet	Voltage	12V
	USB	12V

VIBRATORY SYSTEM		
Frequency	29.5 / 33.5 Hz	
Amplitude	1.9 / 1.2	
Static Linear Load	125 lbs/in	219 N/cm
Centrifugal Force	29,675 / 24,729 lbs	132 / 110 kN

In the interest of continual equipment development, SANY America Inc. reserves the right to change these specifications at any time without prior notification.

DRIVE SYSTEM		
Tires	14.9R24	
Parking Brakes	290-348 Psi	2-2.4 MPa
Gradeability Smooth Drum	50%	
Gradeability Padfoot	40%	
Articulation	+/- 37°	
Oscillation Angle	+/- 12°	

SERVICEABILITY AND FILL CAPACITIES		
Fuel Tank	34.3 gal	130 L
DEF Tank	--	--
Cooling System	10.5 gal	39.7 L
Hydraulic Tank	17.2 gal	65 L
Engine Oil (with filter)	5.3 gal	20 L
Vibratory Drum	2.6 gal	10 L
Drum Final Drive (Reducer)	1.6 gal	6 L
Axle Final Drives	0.5 gal	1.8 L
Rear Axle	5.3 gal	20.0 L
Travel Bearing (Grease)	0.9 gal	3.4 L

SOUND LEVEL		
Operator's Ear in the Cab	76.9 db	
External	103.3 db	

PADFOOT SHELL KIT		
# of Pads	84	
Pad Height	3 in	75 mm
Pad Face Area	10 in ²	65 cm ²

SINGLE DRUM ROLLER



SSR80

STANDARD FEATURES

- Components from brands you trust like Yanmar engines and Danfoss hydraulic motors for dependable performance
- Clear lines of sight and a suspension seat offer operator comfort and job site safety
- Pad foot shell kit comes standard
- ROPS/FOPS Certified

72 hp
Net Power
15,752 lbs
Operating Weight
66"
Drum Width

DIMENSIONS

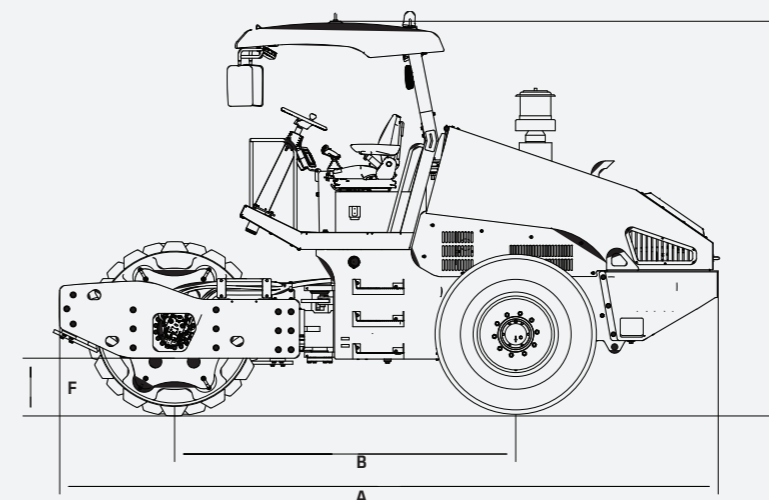
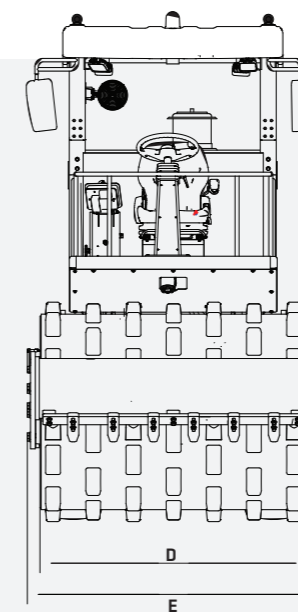

OVERALL DIMENSIONS

A Overall Length	16' 11"	5 160 mm
B Wheelbase	8' 9"	2 675 mm
C Overall Height Smooth Drum	10'	3 050 mm
C Overall Height with Padfoot	10' 3"	3 125 mm
D Drum Width	66"	1 676 mm
E Overall Width	6'	1 830 mm
F Ground Clearance	1' 3"	376 mm
Drum Diameter	4'	1 215 mm
Drum Shell Thickness	0.8"	20 mm
Inside Turning Radius	10' 8"	3 250 mm
Min. Outside Turning Radius	16' 3"	4 950 mm
Curb Clearance	1' 3"	376 mm



*Warranty applies to 2023 Crane, Telehandler, Grader and Roller models only.

SANY America Inc.
318 SANY Way
Peachtree City, Georgia 30269
470.552.SANY

©2023 SANY America Inc. HEXPS23SSR80001

sanyamerica.com

In the interest of continual equipment development, SANY America Inc. reserves the right to change these specifications at any time without prior notification.
©2023 SANY America Inc. HEXPS23SSR80001

PRODUCT SPECIFICATIONS ROLLER ||| SSR80



STANDARD FEATURES

s = standard

SSR80	POWERTRAIN
s	74 hp Yanmar Engine
s	U.S. EPA Tier 4 Final / EU Stage V emissions standards
s	Three speed throttle switch
s	Dual-element dry air filter
s	Flow Divider
s	Electronic engine control
s	Limited slip differential
s	Fuel filter with water separator
s	Full-flow oil filter
s	Turbocharger with charge air cooler
s	500-hour engine oil change interval
s	Engine air precleaner
VIBRATORY SYSTEM	
s	Smooth drum
s	Dual amplitude, dual frequency
s	Auto vibrate function
s	Dual adjustable steel smooth drum scrapers
s	Dual adjustable steel padfoot drum scrapers
s	Padfoot shell kit
ELECTRICAL	
s	24 volt electrical system
s	Ground level electrical disconnect (lockout tag out)
s	850 cold cranking amps battery capacity
s	Positive-terminal battery covers
s	Back-up alarm
s	Emergency stop
s	Rotating beacon light
s	Halogen work lights
s	Indicator and hazard lights all LED

PRODUCT SPECIFICATIONS ROLLER ||| SSR80



STANDARD FEATURES

s = standard

SSR80	OPERATOR'S STATION
s	Open platform with handrails/guardrails
s	3" Seatbelt
s	ROPS/FOPS canopy
s	12 and 24v outlets 60 watt 5 amp
s	Illuminated gauge: diesel exhaust fluid, engine coolant, and fuel levels
s	Horn
s	Hour meter, electric
s	External rearview mirrors
s	Adjustable, tilting steering wheel
s	Multifunction, color LCD monitor with: diagnostic capability / multiple-languages
s	Single lever control for travel and vibration
s	Engine check, engine coolant temperature indicator
s	Light with audible alarm, low-alternator charge indicator light, low-fuel indicator light, low DEF indication with audible alarm, fault code alert indicator, fuel rate display, wiper-mode indicator, work lights on indicator, and work-mode indicator
s	Hydraulic oil filter restriction indicator light
s	Cup holder