

## SINGLE DRUM ROLLER



# SSR80

### STANDARD FEATURES

- Components from brands you trust like Yanmar engines and Danfoss hydraulic motors for dependable performance
- Clear lines of sight and a suspension seat offer operator comfort and job site safety
- Pad foot shell kit comes standard
- ROPS/FOPS Certified

**72 hp**

Net Power

**15,752 lbs**

Operating Weight

**66"**

Drum Width

### DIMENSIONS

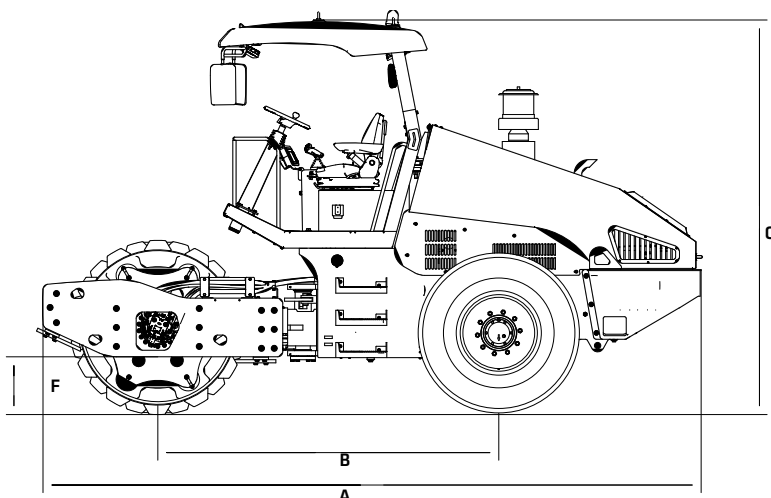
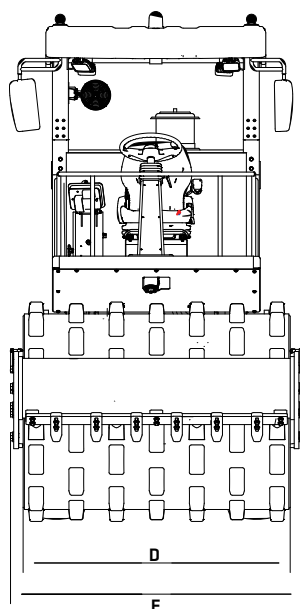

### OVERALL DIMENSIONS

<b>A</b>	Overall Length	16' 11"	5 160 mm
<b>B</b>	Wheelbase	8' 9"	2 675 mm
<b>C</b>	Overall Height Smooth Drum	10'	3 050 mm
<b>C</b>	Overall Height with Padfoot	10' 3"	3 125 mm
<b>D</b>	Drum Width	66"	1 676 mm
<b>E</b>	Overall Width	6'	1 830 mm
<b>F</b>	Ground Clearance	1' 3"	376 mm
	Drum Diameter	4'	1 215 mm
	Drum Shell Thickness	0.8"	20 mm
	Inside Turning Radius	10' 8"	3 250 mm
	Min. Outside Turning Radius	16' 3"	4 950 mm
	Curb Clearance	1' 3"	376 mm



**STANDARD FEATURES**

s = standard

SSR80	POWERTRAIN
s	74 hp Yanmar Engine
s	U.S. EPA Tier 4 Final / EU Stage V emissions standards
s	Three speed throttle switch
s	Dual-element dry air filter
s	Flow Divider
s	Electronic engine control
s	Limited slip differential
s	Fuel filter with water separator
s	Full-flow oil filter
s	Turbocharger with charge air cooler
s	500-hour engine oil change interval
s	Engine air precleaner
VIBRATORY SYSTEM	
s	Smooth drum
s	Dual amplitude, dual frequency
s	Auto vibe function
s	Dual adjustable steel smooth drum scrapers
s	Dual adjustable steel padfoot drum scrapers
s	Padfoot shell kit
ELECTRICAL	
s	24 volt electrical system
s	Ground level electrical disconnect (lockout tag out)
s	850 cold cranking amps battery capacity
s	Positive-terminal battery covers
s	Back-up alarm
s	Emergency stop
s	Rotating beacon light
s	Halogen work lights
s	Indicator and hazard lights all LED

In the interest of continual equipment development, SANY America Inc. reserves the right to change these specifications at any time without prior notification.  
 ©2023 SANY America Inc. HEXPS235SR80001



STANDARD FEATURES

s = standard

SSR80	OPERATOR'S STATION
s	Open platform with handrails/guardrails
s	3" Seatbelt
s	ROPS/FOPS canopy
s	12 and 24v outlets 60 watt 5 amp
s	Illuminated gauge: diesel exhaust fluid, engine coolant, and fuel levels
s	Horn
s	Hour meter, electric
s	External rearview mirrors
s	Adjustable, tilting steering wheel
s	Multifunction, color LCD monitor with: diagnostic capability / multiple-languages
s	Single lever control for travel and vibration
s	Engine check, engine coolant temperature indicator
s	Light with audible alarm, low-alternator charge indicator light, low-fuel indicator light, low DEF indication with audible alarm, fault code alert indicator, fuel rate display, wiper-mode indicator, work lights on indicator, and work-mode indicator
s	Hydraulic oil filter restriction indicator light
s	Cup holder

In the interest of continual equipment development, SANY America Inc. reserves the right to change these specifications at any time without prior notification.  
 ©2023 SANY America Inc. HEXPS235SR80001

# PRODUCT SPECIFICATIONS ROLLER || SSR80

## MACHINE PARAMETERS

### ENGINE

Engine Model	Yanmar 4TNV98CT-VSY	
Emission	Stage V	
Rated Gross Power	72 HP @ 2,100 RPM	53.7kW @ 2100 RPM
Rated Net Power	68 HP @ 2,100 RPM	50.9kW @ 2100 RPM
Max Torque	214 lb-ft	290 N.m @ 1350 RPM
Low Idle / High Idle	1000 rpm / 2250 rpm	1000 rpm / 2250 rpm
Displacement	0.88 gal	3.318 L
Stroke	4.3"	110 mm
Bore	3.9"	98 mm
# of Cylinders	4	
Max. Travel Speed	0~2/0~3 mph; 0~4/0~6 mph	0~6.5/0~7 km/h; 0~8.5/0~12.3 km/h

### WEIGHTS

Operating Weight	15,752 lbs	7 135 kg
Weight at Drum	7,831 lbs	3 552 kg
Weight at Axle	7,899 lbs	3 583 kg
Weight with Padfoot Kit	17,130 lbs	7 770kg

### ELECTRICAL

Battery	Model	6-QW-120MF
	Voltage	12V
	CCA	850 Amp
	Capacity	120 Ah
Alternator	Amp	70 Amp
	Voltage	24V
Power Outlet	Voltage	12V
	USB	12V

### VIBRATORY SYSTEM

Frequency	29.5 / 33.5 Hz	
Amplitude	1.9 / 1.2	
Static Linear Load	125 lbs/in	219 N/cm
Centrifugal Force	29,675 / 24,729 lbs	132 / 110 kN

In the interest of continual equipment development, SANY America Inc. reserves the right to change these specifications at any time without prior notification.

### DRIVE SYSTEM

Tires	14.9R24	
Parking Brakes	290~348 Psi	2~2.4 MPa
Gradeability Smooth Drum	50%	
Gradeability Padfoot	40%	
Articulation	+/- 37°	
Oscillation Angle	+/- 12°	

### SERVICEABILITY AND FILL CAPACITIES

Fuel Tank	34.3 gal	130 L
DEF Tank	--	--
Cooling System	10.5 gal	39.7 L
Hydraulic Tank	17.2 gal	65 L
Engine Oil (with filter)	5.3 gal	20 L
Vibratory Drum	2.6 gal	10 L
Drum Final Drive (Reducer)	1.6 gal	6 L
Axle Final Drives	0.5 gal	1.8 L
Rear Axle	5.3 gal	20.0 L
Travel Bearing (Grease)	0.9 gal	3.4 L

### SOUND LEVEL

Operator's Ear in the Cab	76.9 db	
External	103.3 db	

### PADFOOT SHELL KIT

# of Pads	84	
Pad Height	3 in	75 mm
Pad Face Area	10 in <sup>2</sup>	65 cm <sup>2</sup>

# SANY

SANY America Inc.  
318 SANY Way  
Peachtree City, Georgia 30269  
470.552.SANY

©2023 SANY America Inc. HEXPS23SSR80001



[sanyamerica.com](http://sanyamerica.com)



\*Warranty applies to 2023 Crane, Telehandler, Grader and Roller models only.