

# BACKHOE LOADER

# SLB95

## STANDARD FEATURES

- ➔ Quick coupler plumbing to end of stick
- ➔ Loader parallel lift
- ➔ Flip over pads with cylinder guards
- ➔ Return to dig
- ➔ Cab or Canopy Configuration
- ➔ Dedicated breaker circuit

**95 hp**

Net Power

**14' 3"**

Dig Depth

**16,623 lbs**

Operating Weight(Cab, No Attachments)

**1.3 yd<sup>3</sup>**

Loader Bucket Capacity

**0.34 yd<sup>3</sup>**

Excavator Bucket Capacity

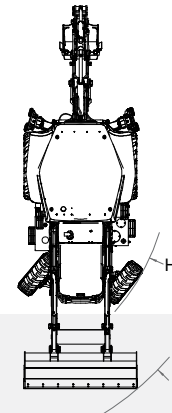
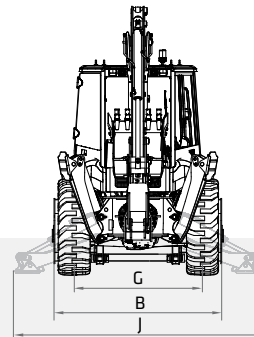
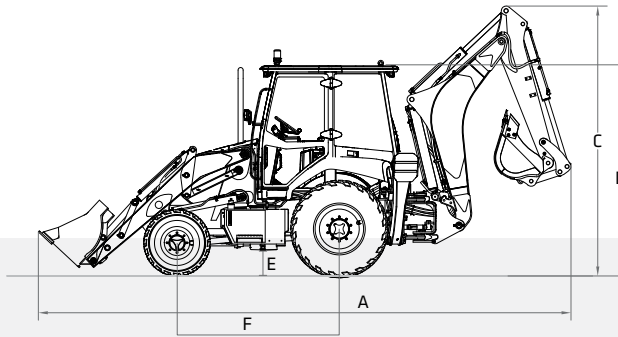

## TECHNICAL SPECIFICATIONS

### TECHNICAL SPECIFICATIONS

Cab with all attachments	17,725 lbs	8 040 kg
Canopy with all attachments	17,372 lbs	7 880 kg
Cab without attachments	16,623 lbs	7540 kg
Canopy without all attachments	16,226 lbs	7360 kg
<b>Engine</b>	Deutz TCD3.6-L4 - Low Maintenance T4F	
Displacement	220 in <sup>3</sup>	3.6 L
Gross Power	99 hp @ 2200 rpm	73.8 kW @ 2200 rpm
Net Power	95 hp @ 2200 rpm	70.8 kW @ 2200 rpm
Maximum Torque	302.4 lbs-ft @1600 rpm	410 Nm @ 1600 rpm
<b>Transmission</b>	ZF 4WD - 4 Speed Forward/Reverse	
Speed Gear 1	3 mph	4.8 km/hr
Speed Gear 2	6 mph	9.6 km/hr
Speed Gear 3	12 mph	19.3 km/hr
Speed Gear 4	22 mph	35.4 km/hr
<b>Hydraulics</b>	Load Sensing with Pilot Controls	
Main Hydraulic Pump	Kawasaki Variable Displacement-Axial Piston	
Hydraulic Power	52.3 hp @ 2200 rpm	39 kW @ 2,200 rpm
System Flow	41.2 gal/min	156 l/min
Operating Pressure	3,625 psi	24.9 MPa
One-way Aux Line Max Flow	21 gal/min	79.4 l/min
One-way Aux Line Max Pressure	2,103 psi	14.5 MPa

## DIMENSIONS

### DIMENSIONS

A Overall Length, Transport	24' 3"	7 381 mm
B Overall Width, Transport	7' 6"	2 280 mm
C Transport Height	12' 3"	3 732 mm
D Cab Roof Height	10' 3"	3 129 mm
E Ground Clearance	1' 1"	320 mm
F Length from Axle to Axle	7' 4"	2 245 mm
G Wheel Base, Rear	5' 10"	1 780 mm
H Turning Radius, Front Tires	13' 11"	4 240 mm
I Turning Radius, Front Bucket	15' 9"	4 800 mm
J Stabilizer Overall Width	11' 5"	3 491 mm

### SERVICE REFILL CAPACITIES

Fuel Tank Capacity	37.0 gal	140.0 L
DEF Tank Capacity	2.6 gal	10.0 L
Hydraulic Oil Capacity	31.7 gal	120.0 L
Engine Oil Capacity	2.2 gal	8.5 L
Cooling System Capacity	5.3 gal	20.0 L
Gear Box Oil Capacity	4.8 gal	18.0 L

\*Based on theoretical calculation at max flow with no load. Subject to alterations. In the interest of continual equipment development

SANY America Inc. reserves the right to change these specifications at any time without prior notification. ©2023 SANY America Inc. PS23SLB95001



STANDARD AND OPTIONAL EQUIPMENT

s = standard / o = optional

SLB95	ENGINE
s	3.6l Deutz TCD-L4 - Tier 4 Final Certified
s	Auto-idle
s	Dual-element air filter
s	Electronic engine control
s	Enclosed fan guard
s	Fuel filter with water separator
s	Turbocharger with charge air cooler
s	Sever-duty fuel filter
HYDRAULIC SYSTEM	
s	Auxiliary hydraulic-flow adjustments through monitor
s	Control pattern change valve
s	Auxiliary hydraulics with 1- way piping with shut-off valve
s	Auxiliary pilot controls
TRANSMISSION	
s	4WD powershift transmission
s	Heavy duty axles
s	4-speed F/R
s	Front tires 12-16.5 12PR AEX3
s	Rear tires 19.5-24 14PR R-4
s	Drive shaft guard
s	Electronic controlled gearbox
WORKING EQUIPMENT	
s	Boom 2.6m (8 ft. 7 in.)
s	Stick, 2.3 m (7 ft. 7 in.)
s	Flip-over pads with cylinder guards
s	Loader parallel lift
s	Loader float function
s	Return-to-dig
UPPERSTRUCTURE	
s	Rear mirror
s	Rubber front bumpers
s	Loader service safety lock
ATTACHMENTS	
s	Oil-impregnated bushings
s	Reinforced resin thrust plates
s	Convenient grease points
s	Dirt seals on all bucket pins

In the interest of continual equipment development, SANY America Inc. reserves the right to change these specifications at any time without prior notification.  
 ©2023 SANY America Inc. PS23SLB95001



\*Warranty applies to 2023 backhoe loader models only.



STANDARD AND OPTIONAL EQUIPMENT

s = standard / o = optional

SLB95	OPERATOR'S STATION
s	Adjustable independent-control positions (levers-to-seat, seat-to-pedals, and steering wheel)
s	AM/FM radio with USB charging and Bluetooth® connectivity
s	Auto climate control / air conditioner / heater / pressurizer(Cab Only)
s	Built-in operator's manual storage compartment and manual
s	24v outlet
s	Deluxe heated air suspension cloth seat, with adjustable armrests
s	Heavy duty rubber floor mat
s	Front/rear windshield wiper with variable speeds
s	Illuminated gauge: diesel exhaust fluid, engine coolant, and fuel levels
s	Horn, electric
s	Hour meter, electric
s	Hydraulic shutoff lever, all controls
s	Interior light
s	Large cup holder
s	Digital throttle
s	System monitoring with alarm features: Auto-idle indicator, engine air cleaner
s	Restriction indicator light, engine check, engine coolant temperature indicator
s	Hydraulic oil filter bypass; Parking brake engagement; low fuel; water in fuel; low DEF.
s	Seat belt, 3 in., retractable
s	ROPS/FOPS
ELECTRICAL	
s	120-amp alternator
s	Ground level electrical disconnect
s	Positive terminal battery covers
s	165 Ah and 850 CCA battery
LIGHTS	
s	Work lights: 4 front and 4 rear
s	Rotating beacon

In the interest of continual equipment development, SANY America Inc. reserves the right to change these specifications at any time without prior notification.  
 ©2023 SANY America Inc. PS23SLB95001



# PRODUCT SPECIFICATIONS BACKHOE LOADER ||| SLB95

## WORKING RANGE

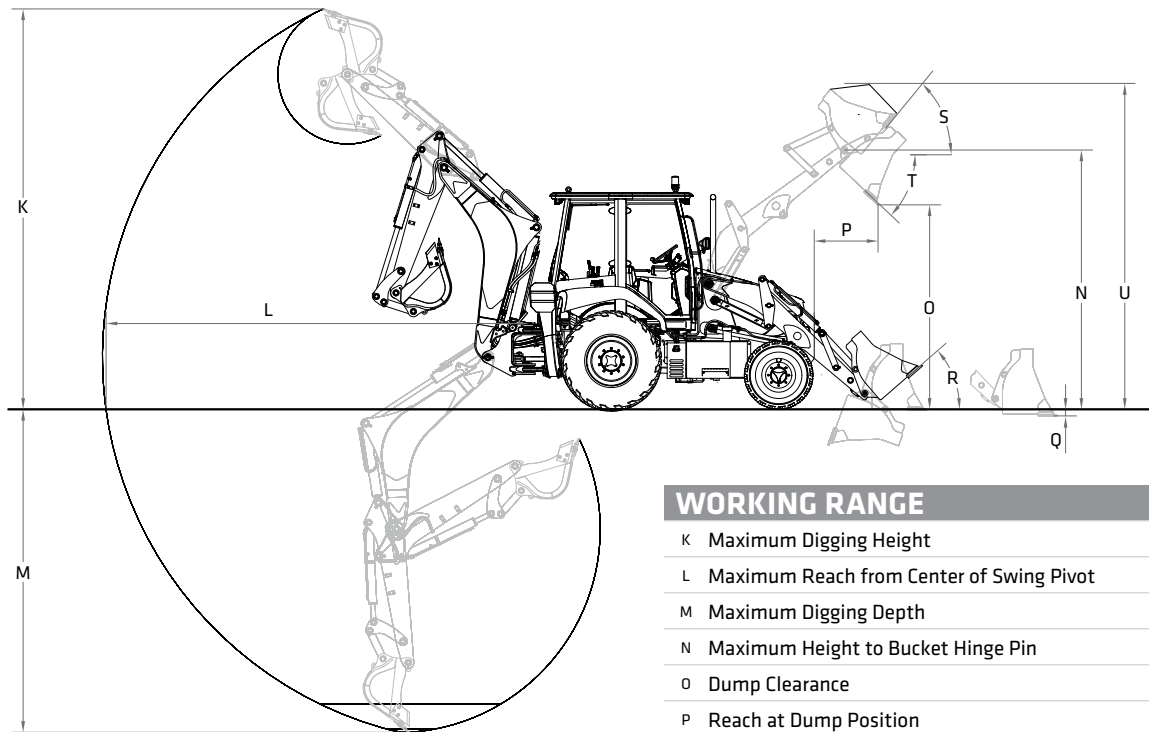

### WORKING RANGE

K	Maximum Digging Height	17' 7"	5 370 mm
L	Maximum Reach from Center of Swing Pivot	18' 7"	5 671 mm
M	Maximum Digging Depth	14' 3"	4 332 mm
N	Maximum Height to Bucket Hinge Pin	11' 5"	3 478 mm
O	Dump Clearance	8' 10"	2 700 mm
P	Reach at Dump Position	2' 5"	730 mm
Q	Maximum Digging Depth with Bucket Leveled	3"	88 mm
R	Bucket Rollback Angle @ Ground Level	40°	
S	Bucket Rollback Angle @ Full Height	51°	
T	Loader Dump Angle @ Full Height	44°	
U	Maximum Operating Height	14' 1"	4 293 mm

### DIGGING PERFORMANCE

Bucket Breakout Force—Excavator	12,354 lbf	55 kN
Bucket Breakout Force—Loader	11,240 lbf	50 kN

## LIFTING FORCE

	POSITION	IMPERIAL	METRIC
BOOM	1	3,005 lbs	1 363 kg
	2	2,619 lbs	1 188 kg
	3	2,778 lbs	1 260 kg
	4	2,696 lbs	1 223 kg
	5	2,571 lbs	1 166 kg
	6	2,414 lbs	1 095 kg
	7	2,344 lbs	1 063 kg
	8	2,286 lbs	1 037 kg
	9	2,423 lbs	1 099 kg
	10	3,845 lbs	1 744 kg
ARM	11	2,844 lbs	1 290 kg
	12	3,735 lbs	1 694 kg
	13	5,941 lbs	2 695 kg
	14	5,816 lbs	2 638 kg
	15	6,579 lbs	2 984 kg
	16	7,683 lbs	3 485 kg
	17	9,504 lbs	4 311 kg

\* Indicates load limited by hydraulic lifting capacity.

