

SMG200C-8

PRODUCT  
SPECIFICATIONS

SANY



## STANDARD FEATURES

- 14-foot blade to quickly handle even large jobs
- Joystick controls for grading and steering wheel for roading offer simple-to-learn operation
- Air-conditioned cab and heated air ride seat standard for operator comfort
- Open cab design with rear-view camera maximizes line of sight and visibility

Engine Output - Net  
**253 hp / 186 kW**

Operating Weight  
**45,768 lb / 20 760 kg**

Moldboard Width  
**14 ft / 4 270 mm**

# PRODUCT SPECIFICATIONS

# SANY SMG200C-8

## Machine Parameters

### ENGINE

Engine Model	Cummins QSL9-C250	
Engine Net Power	253 hp	186 kW
Torque Rated Speed	1,500 rpm	
Displacement	543.1 in <sup>3</sup>	8.9 L
Turbo Charged with Intercooler	Yes	

### OPERATING

Frame Type	Articulated	
Moldboard	14 ft	4 270 mm
Moldboard - Cutting Depth	28.15 in	715 mm
Moldboard Height	24.41 in	620 mm
Moldboard - Lift Above Ground	18.9 in	480 mm
Frame Articulation	22°	
Front Wheel Lean	17°	
Axle Oscillation	16°	
Turning Radius - Minimum	295.28 in	7.5 m
Transport Width	107.28 in	2 725 mm
Fuel Tank	89.82 gal	340 L
Telematics Available	Yes	

### POWERTRAIN

Drive Configuration	6 x 4	
Traction Aid	Manual Differential Lock	
Service Brake Type	Wet Multiple-Disc	
Number of Axles	2	
Tire Size - Standard	17.5-25	

### TRANSMISSION

Transmission Type	Direct-Drive, Power Shift	
Number of Speeds	8-Forward	

### WEIGHT

Operating Weight	45,107 lb	20 460 kg
Operating Weight - Maximum	45,768 lb	20 760 kg
Loading - Rear Axle / Tandem	33,808 lb	15 335 kg
Blade Down Pressure	19,925 lbf	9 038 kgf

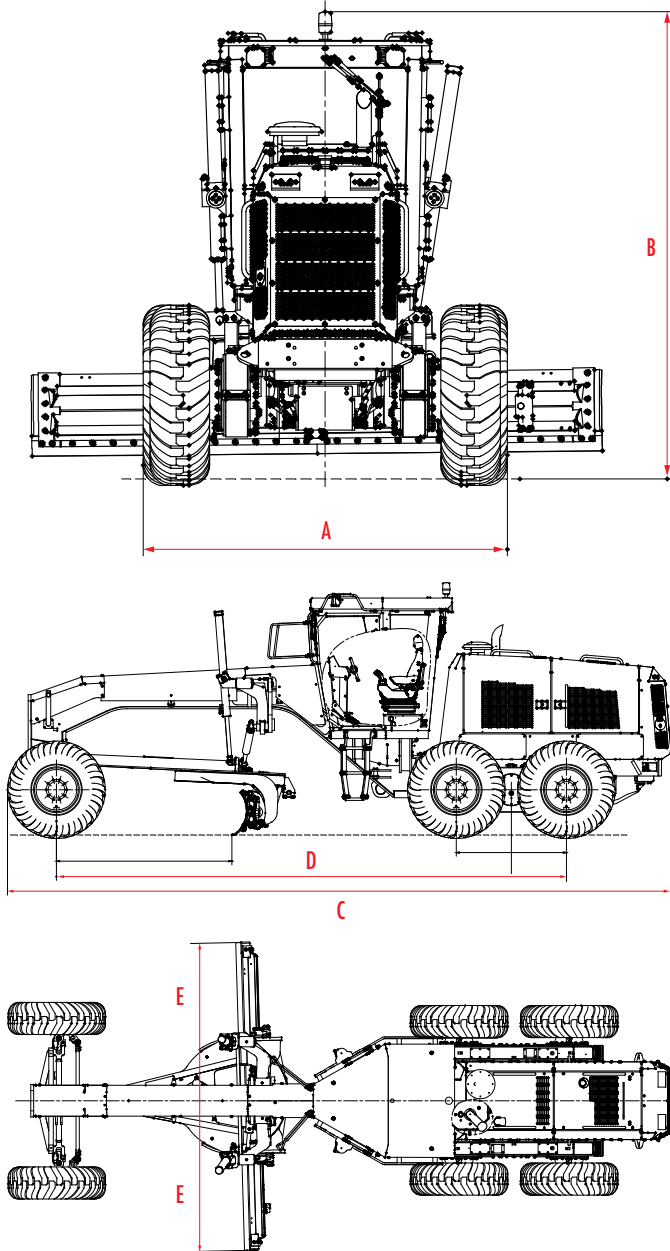

## OVERALL DIMENSIONS

	STANDARD	METRIC
A Width Over Std Tires	107.28"	2 725 mm
B Height Over ROPS	137.72"	3 498 mm
C Overall Length	361.69"	9 187 mm
D Wheelbase (F/R)	248.03"	6 300 mm
E Width - Moldboard	14'	4 270 mm

In the interest of continual equipment development, SANY America, Inc. reserves the right to change these specifications at any time without prior notification.