

PRODUCT SPECIFICATIONS EXCAVATOR || SY60C

WORKING RANGE

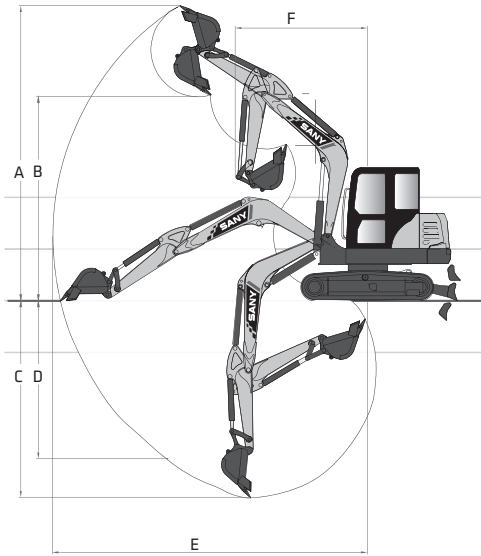

WORKING RANGE		
Boom Length	9' 10"	3 000 mm
Stick Length	5' 7"	1 700 mm
A Maximum Digging Height	18' 11"	5 778 mm
B Maximum Dumping Height	13' 4"	4 050 mm
C Maximum Digging Depth	13' 0"	3 961 mm
D Maximum Vertical Wall Digging Depth	10' 5"	3 188 mm
E Maximum Reach at Ground Level	20' 2"	6 146 mm
F Minimum Swing Radius	8' 8"	2 640 mm

DIGGING PERFORMANCE		
Boom Length	9' 10"	3 000 mm
Stick Length	5' 7"	1 700 mm
Bucket Breakout Force (ISO)	10,116 lbf	45.0 kN
Stick Digging Force (ISO)	7,419 lbf	33.0 kN

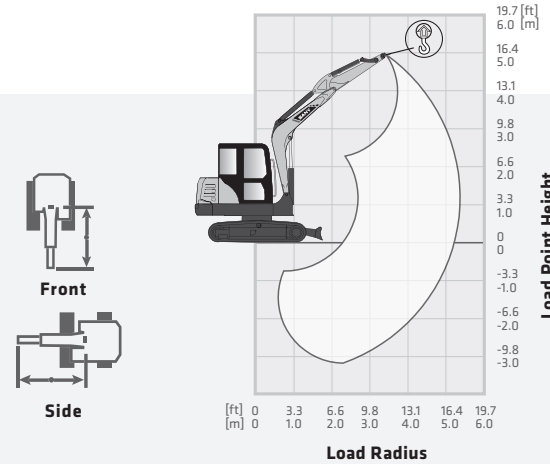

LIFTING PERFORMANCE

Standard 9' 10" (3 000 mm) Boom
Standard 5' 7" (1 700 mm) Stick
Standard 16" (400 mm) Track Shoes
No Bucket

Ratings are based on ISO 10567:2007. Lift capacity does not exceed 75% of tipping load with the machine on firm, level ground or 87% of hydraulic lifting capacity.

LOAD RADIUS	6.6 ft 2.0 m		9.8 ft 3.0 m		13.1 ft 4.0 m		16.4 ft 5.0 m		MAX REACH	
	BLADE DOWN	BLADE UP	BLADE DOWN	BLADE UP	BLADE DOWN	BLADE UP	BLADE DOWN	BLADE UP	BLADE DOWN	BLADE UP
13.1 ft 4.0 m					2,205 lb* 1 000 kg*	2,205 lb* 1 000 kg			2,425 lb* 1 100 kg*	1,874 lb 850 kg
9.8 ft 3.0 m					2,535 lb* 1 150 kg*	2,205 lb* 1 000 kg		2,425 lb* 1 100 kg*	1,433 lb 650 kg	1,433 lb 650 kg
6.6 ft 2.0 m			3,968 lb* 1 800 kg*	3,086 lb 1 400 kg	2,976 lb* 1 350 kg*	2,094 lb 950 kg	2,646 lb* 1 200 kg*	1,433 lb 650 kg	2,646 lb* 1 200 kg*	1,323 lb 600 kg
3.3 ft 1.0 m			5,401 lb* 2 450 kg*	2,756 lb 1 250 kg	3,638 lb* 1 650 kg*	1,874 lb 850 kg	2,976 lb* 1 350 kg*	1,433 lb 650 kg	2,756 lb* 1 250 kg*	1,213 lb 550 kg
0 ft 0 m			6,173 lb* 2 800 kg*	2,646 lb 1 200 kg	4,079 lb* 1 850 kg*	1,764 lb 800 kg	3,086 lb* 1 400 kg*	1,323 lb 600 kg	2,976 lb* 1 350 kg*	1,323 lb 600 kg
-3.3 ft -1.0 m	8,378 lb* 3 800 kg*	5,291 lb 2 400 kg	6,063 lb* 2 750 kg*	2,646 lb 1 200 kg	4,079 lb* 1 850 kg*	1,764 lb 800 kg			3,197 lb* 1 450 kg*	1,433 lb 650 kg
-6.6 ft -2.0 m	8,818 lb* 4 000 kg*	5,181 lb 2 350 kg	5,401 lb* 2 450 kg*	2,646 lb 1 200 kg	3,417 lb* 1 550 kg*	1,874 lb 850 kg			3,417 lb* 1 550 kg*	1,874 lb 850 kg
13.1 ft 4.0 m					2,205 lb* 1 000 kg*	2,205 lb* 1 000 kg			2,205 lb* 1 000 kg*	1,874 lb 850 kg
9.8 ft 3.0 m					2,205 lb* 1 000 kg*	2,205 lb* 1 000 kg	1,984 lb* 900 kg*	1,433 lb 650 kg	1,984 lb* 900 kg*	1,433 lb 650 kg
6.6 ft 2.0 m			3,968 lb* 1 800 kg*	3,086 lb 1 400 kg	2,866 lb* 1 300 kg*	2,094 lb 950 kg	1,984 lb* 900 kg*	1,433 lb 650 kg	1,764 lb* 800 kg*	1,323 lb 600 kg
3.3 ft 1.0 m			3,968 lb* 1 800 kg*	2,756 lb 1 250 kg	2,646 lb* 1 200 kg*	1,874 lb 850 kg	1,948 lb* 900 kg*	1,433 lb 650 kg	1,764 lb* 800 kg*	1,213 lb 550 kg
0 ft 0 m			3,858 lb* 1 750 kg*	2,646 lb 1 200 kg	2,535 lb* 1 150 kg*	1,764 lb 800 kg	1,874 lb* 850 kg*	1,323 lb 600 kg	1,764 lb* 800 kg*	1,323 lb 600 kg
-3.3 ft -1.0 m	7,937 lb* 3 600 kg*	5,291 lb 2 400 kg	3,858 lb* 1 750 kg*	2,646 lb 1 200 kg	2,535 lb* 1 150 kg*	1,764 lb 800 kg			1,984 lb* 900 kg*	1,433 lb 650 kg
-6.6 ft -2.0 m	8,157 lb* 3 700 kg*	5,181 lb 2 350 kg	3,968 lb* 1 800 kg*	2,646 lb 1 200 kg	2,646 lb* 1 200 kg*	1,874 lb 850 kg			2,646 lb* 1 200 kg*	1,874 lb 850 kg

* Indicates load limited by hydraulic lifting capacity.

In the interest of continual equipment development, SANY America Inc. reserves the right to change these specifications at any time without prior notification. ©2024 SANY America Inc. HEXPS24SY60CISU004

SANY America Inc. 318 SANY Way
Peachtree City, Georgia 30269
470.552.SANY sanyamerica.com



PRODUCT SPECIFICATIONS



EXCAVATOR

||| SY60C
Isuzu Engine

STANDARD FEATURES

- Swing boom functionality
- Conventional tail swing
- 1-way and 2-way primary auxiliary circuit
- Quick coupler plumbing to end of stick
- Powerful Isuzu Engine

55.9 hp
Net Power
13'
Dig Depth
13,448 lbs
Operating Weight
10,116 lbf
Bucket Breakout

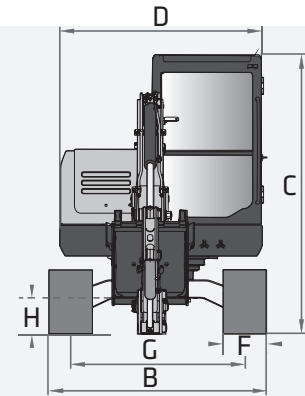
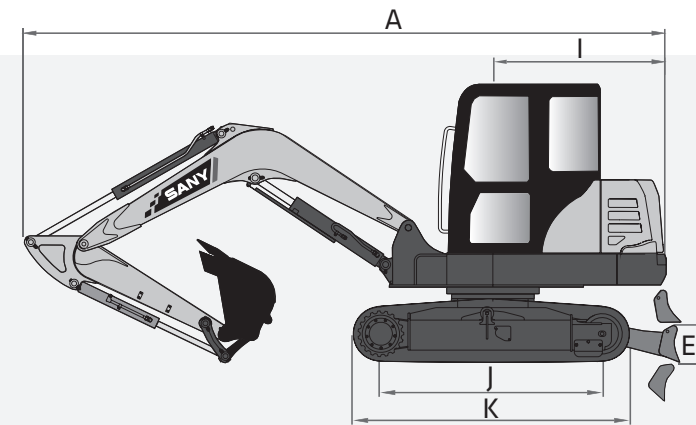

TECHNICAL SPECIFICATIONS

TECHNICAL SPECIFICATIONS		
Operating Weight	13,448 lbs	6 100 kg
Ground Pressure	5.0 psi	34.6 kPa
Engine	4LE2X	
Displacement	133.0 in ³	2.18 L
Gross Power	57.6 HP	43.0 kW
Net Power	55.9 HP	41.7 kW
Hydraulics	Load Sensing with Pilot Control	
Main Hydraulic Pump	Axial Piston - Variable Displacement	
Operating Flow (maximum)	37.7 gal/min	142.7 L/min
Operating Pressure (maximum)	3,553 psi	24.5 MPa
Auxiliary Flow (maximum)*	23.8 gal/min	90 L/min
Auxiliary Pressure (maximum)	3,626 psi	25 MPa
Travel Motor	Axial Piston with Park Brake	
Travel Pressure (maximum)	3,553 psi	24.5 MPa
Travel Speeds (maximum)	1.5 / 2.3 mph	2.4 / 3.7 km/hr
Travel Effort (maximum)	10,611 lbf	47.2 kN
Grade Capability (maximum)	35°	
Swing Motor	Axial Piston with Swing Brake	
Swing Pressure (maximum)	2,770 psi	19.1 MPa
Swing Speed (maximum)	9.6 RPM	
Undercarriage (standard)	Belted Rubber Track	
Track Shoe Width (standard)	16"	400 mm
Track Rollers (per side)	5	
Carrier Rollers (per side)	1	

*Based on theoretical calculation at max flow with no load. Subject to alterations. In the interest of continual equipment development.

DIMENSIONS

DIMENSIONS		
Boom Length	9' 10"	3 000 mm
Stick Length	5' 7"	1 700 mm
A Transport Length	19' 9"	6 015 mm
B Transport Width	6' 7"	2 005 mm
C Transport Height	8' 8"	2 645 mm
D Upper Structure Width	6' 1"	1 860 mm
E Blade Height	13"	340 mm
F Track Width (standard shoe)	16"	400 mm
G Track Gauge	5' 3"	1 600 mm
H Ground Clearance (minimum)	13"	330 mm
I Tail Swing Radius	5' 5"	1 640 mm
J Track Length on Ground	6' 9"	2 045 mm
K Track Length	8' 4"	2 545 mm

SERVICE REFILL CAPACITIES

Fuel Tank Capacity	34.3 gal	130.0 L
Hydraulic Tank Capacity	22.5 gal	85.0 L
Engine Oil Capacity	2.5 gal	9.6 L
Cooling System Capacity	1.5 gal	5.6 L

SANY America Inc. reserves the right to change these specifications at any time without prior notification. ©2024 SANY America Inc. HEXPS24SY60CISU004



STANDARD AND OPTIONAL EQUIPMENT

s = standard / o = optional

SY60C	ENGINE
s	Isuzu 4LE2X
s	Tier 4F / EU Stage V Ready
s	Auto-idle
s	Dual-element dry air filter
s	Engine air precleaner
s	Coolant Expansion tank
s	Electronic engine control
s	Fan guard
s	Engine coolant to -37 deg. C (-34 deg. F)
s	Full-flow oil filter
s	High flow cooling fan
s	500-hour engine-oil-change interval
s	No scheduled DPF maintenance for 6000 hours
s	Fuel filter and water separator
HYDRAULIC SYSTEM	
s	Spring-applied, hydraulically released automatic swing brake
s	Load sensing hydraulic system
s	Control pattern change valve
s	Primary auxiliary hydraulic circuit with 1 and 2-way combination piping
s	Auxiliary hydraulic-flow adjustments through monitor
s	Adjustable auxiliary pressure relief
s	Quick coupler ready
UNDERCARRIAGE	
s	Planetary drive with axial piston motors
s	Propel motor shields
s	Spring-applied, hydraulically released automatic propel brake
s	Track guides, front idler and 2 per side
s	2-speed travel selection through display
s	5 lower track rollers each side
s	1 upper carrier roller each side
s	Dozer blade with cylinder guarding
s	Tie downs on track frame and dozer blade
s	400mm (16") wide rubber tracks
o	400mm (16") wide steel tracks
s	Undercarriage frame opening guard
UPPERSTRUCTURE	
s	Right-hand, left-hand, and counterweight mirrors
s	Lockable cab, hood, and service doors
s	Debris screen in side panel
s	Remote-mounted engine oil and fuel filters
s	Daily fluid level inspection visible from ground
s	Rear reflectors
ATTACHMENTS	
s	Convenient grease points
s	Centralized lubrication system
s	Dirt seals on all bucket pins
s	Thumb bracket

In the interest of continual equipment development, SANY America Inc. reserves the right to change these specifications at any time without prior notification.
©2024 SANY America Inc. HEXPS24SY60CISU004



STANDARD AND OPTIONAL EQUIPMENT

s = standard / o = optional

SY60C	ATTACHMENTS
s	Oil-impregnated bushings
s	Reinforced thrust plates
s	Quick coupler plumbing to end of the stick
OPERATOR'S STATION	
s	Hydraulic pilot controls for boom, stick, swing, and travel operations
s	Proportional auxiliary switches on joystick
s	Travel levers with foot pedals
s	AM/FM radio with bluetooth and USB connection port
s	Cell phone tray
s	Weight adjustable suspension cloth seat with fore/aft adjustment and adjustable armrests
s	2" seat mounted lap belt
s	Emergency stop switch
s	Sliding front window
s	Removable lower front window
s	Window breaker
s	ECO mode switch
s	8 tool selection modes
s	Fully adjustable auxiliary flow circuits and pressure from display
s	Multifunction color LCD monitor with: diagnostic capability / multiple-language
s	System monitoring features: auto-idle indicator, 2-speed indicator, work-mode indicator, preheat icon, time and date, battery charge icon, throttle position, engine oil pressure alarm, DPF regeneration inhibit indicator, fuel level gauge, maintenance needed icon, failure code, standard/eco work mode icon, engine coolant temperature, coolant temp alarm, severe failure alarm, work tool mode icon, operating hours
s	High performance heating, ventilation, and air conditioning system
s	Operation and maintenance manual storage
s	Heavy duty removeable rubber floor mat
s	Front windshield wiper with high and low speed
s	Horn, electric
s	Hour meter, electric
s	Hydraulic shutoff lever, all controls
s	Interior light
s	Cup holder
s	Travel alarm with cancel switch
s	Transparent overhead hatch with retractable sun shade
ELECTRICAL	
s	24V electrical system
s	Maintenance free battery
s	Ground level battery disconnect
s	Easy access fuse panel
s	Terminal battery covers
s	80-amp alternator
s	12V power outlet
LIGHTS	
s	Work lights: 2 mounted on top of cab, 1 mounted on boom, magnetic beacon

In the interest of continual equipment development, SANY America Inc. reserves the right to change these specifications at any time without prior notification.
©2024 SANY America Inc. HEXPS24SY60CISU004



*Warranty applies to 2024 Excavator and Wheel Loader models

